

XXIII. *On the means of facilitating the observation of distant stations in geodætical operations.* By Lieutenant THOMAS DRUMMOND, of the Royal Engineers. Communicated April 14, 1826, by Lieut. Colonel H. COLBY, F. R. S.

Read May 4, 1826.

IN consequence of the Report of a Select Committee of the House of Commons in June 1824, it was resolved, that a new Survey of Ireland should be immediately undertaken.

The necessity of carrying on this extensive work with the utmost degree of rapidity, consistent with accuracy of execution, being strongly urged in the Report to which I have alluded, the arrangements were directed to be made on a suitable scale, and every method to be adopted that seemed likely to contribute to this end. The triangulation, as forming the basis of the survey, and the means of accelerating its execution, claimed immediate attention; and I was directed by Colonel COLBY, at that time actively engaged in making the necessary preparations for this important undertaking, to consider by what means our distant stations might be rendered more frequently observable than the state of the atmosphere usually permits.

From this source, at least in this country, arises the chief delay in carrying on such operations; and the experience of a previous season among the Western Islands, had shown the probability of this impediment being materially increased, and more than ordinary difficulty encountered, in effecting

the triangulation of Ireland, and in connecting that country with the western shores of Scotland and England. The connecting triangles are large, many of the sides being 60, 70, and 80 miles. The means resorted to for rendering these distant stations visible in ordinary states of the weather, and their successful application on some occasions of difficulty that presented themselves at the close of last year's operations, form the subject of the communication which I have now the honour of submitting to this Society.

The reflection of the sun from a plane mirror, as affording a point of observation that might be seen at remote distances, was suggested and employed by Professor GAUSS in 1822, while engaged with a trigonometrical measurement in Hanover; and the result of the first trials made at Inselberg and Hohenhagen, rendered it highly probable that it might be applied with much advantage to this purpose.

The principle was adopted in this country when Colonel COLBY and Captain KATER were engaged, in 1822, in verifying General ROY's triangulation connecting the meridians of Paris and Greenwich. At their concluding station on Shooter's Hill, seven or eight days had elapsed, during which Hanger Hill Tower, though only 10 miles distant, having remained completely obscured by the dense smoke of London, tin plates were attached to the signal post, so as to reflect the sun towards the station at stated times on a certain day.

At the hours for which they had been calculated these plates became visible, and the observations were in consequence immediately and easily completed. In the subsequent operations of 1823, recourse was again had on two important occasions to the same method, and with equal success. I

allude to Leith Hill, near Dorking, in Surrey, and Wrotham Hill, in Kent, stations which it was of the utmost consequence to observe from Berkhamstead Tower, near Hertford. Our efforts to effect these observations having for some time been rendered unavailing by the thick mist, so frequently overhanging the bed of the Thames, a series of bright tin plates was put up on both stations. Each set consisting of six or eight plates, was attached to a smooth flat board, placed vertically by the plumb line, and turning on a pivot: the respective inclinations of the plates with the face of the board being determined, so that they might have the positions required for reflecting, in succession, the sun's rays towards Berkhamstead tower, when the surface of the board was turned at right angles to the line of direction. Although this method admitted but of rude execution, it fully answered the purpose for which it was employed: the plates became visible in succession at the appointed hours, the duration of each varying with the inequality of its surface, but being generally from ten to fifteen minutes; they were seen nearly at the same hours for some days before and after that for which they were calculated.

The distance to Leith Hill is 45 miles, and the observations were in this way completed without the hill itself having been visible during the whole of our stay, which was nearly three weeks.

The utility of employing the sun's reflection as a point of observation being established by the result of these experiments, it only remained, instead of a temporary expedient, rather difficult of execution, to substitute an instrument that might be used on all occasions, simple

in its construction, and easy of management. Fig. 1, Plate XII. represents an instrument contrived with this view, which was employed last year in Ireland with much advantage. ab is a telescope of 12 inches focal length, and serves as the axis of the instrument; the bars bd and bc form a right angle; and the bar gg , placed so that bf (fig. 2), shall be equal to fg , works between bd and bc , carrying a small telescope, such as is usually attached to sextants, and provided with a rectangular eye-piece. The mirror mm , of which different sizes may be used according to circumstances, is connected with the instrument by three adjusting screws r . The bars bc , $b'c'$, being now made to coincide with ab , a moveable spirit level is placed across them in the position ll , fig. 2, and rendered horizontal by the foot screws; by the same means the axis ab , to which a level is permanently attached, is also brought into a horizontal position. The moveable spirit level being now transferred to the surface of the mirror, the three adjusting screws r , are employed to render it horizontal. The mirror will then be parallel to ab and ll , and will have the required position on the instrument. The telescope ab being now directed upon the object to which the reflection is to be thrown, and the small telescope gg turned towards the sun, its rays will then be reflected parallel to the axis of the instrument ab . The head of the screw R , fig. 2, is graduated, so that by means of it and the spirit level attached to the axis, the required elevation or depression may be given to the instrument when the object towards which it is directed happens to be invisible, its direction only being known relatively to some nearer object; and which, it may be remarked, has been the case in every instance in which it

has been employed on the survey. When packed for travelling, the mirror *mm* is detached, and the bar *gg* turned till it coincides with *bf*. The instrument once directed, its management was usually confided to one of the non-commissioned officers.

To combine, with the heliostat now described, a means of exhibiting a bright light at night, that no opportunity might be lost of effecting our purpose, was the next consideration.

In the beginning of the survey, General ROY had, on several occasions, but especially in carrying his triangles across the Channel to the French coast, made use of Bengal and white lights prepared at the Royal Arsenal: for these, parabolic reflectors, similar to those with which our light-houses are supplied, and illuminated by argand burners, were afterwards substituted, as more convenient; but they have been gradually discontinued, the advantages derived from them proving inadequate, from their want of power, to the trouble and expense incident to their employment. In the trigonometrical operations of 1821 carried on by Colonel COLBY and Captain KATER, conjointly with MM. ARAGO and MATHIEU, for connecting the meridians of Greenwich and Paris, an apparatus of a very different kind was employed for the first time. A large plano-convex lens 0.76 metre square being substituted for a parabolic reflector, and the illuminating body an argand lamp with four concentric wicks. The lens was composed of a series of concentric rings, reduced in thickness and cemented together at the edges. This apparatus resulted from an inquiry into the state of the French light-houses, and was prepared under the direction of MM. FRESNEL and ARAGO. Its construction and advan-

Fig. 1.

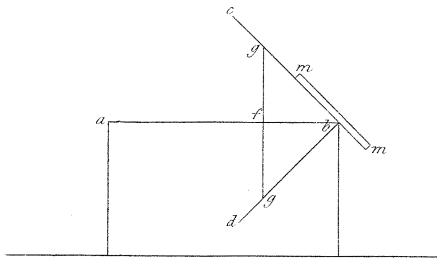
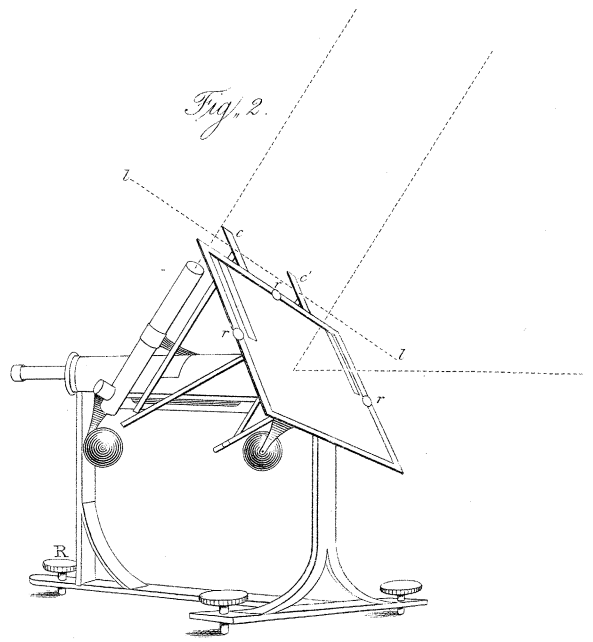
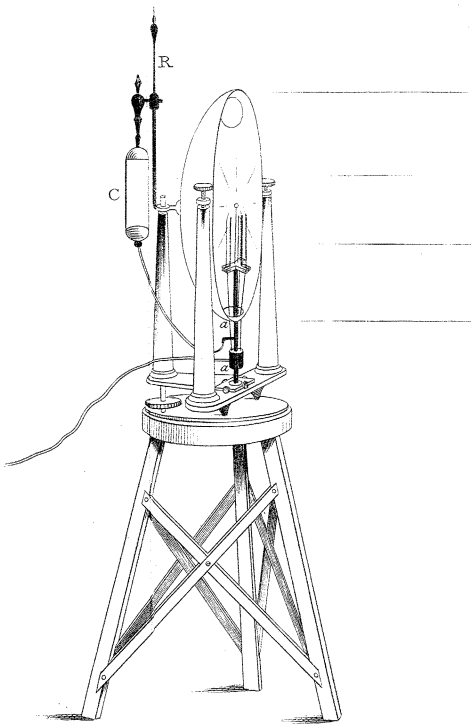

Fig. 2.



One Inch to One Foot.

Fig. 3.



One Inch to Eighteen Inches.

Fig. 4.

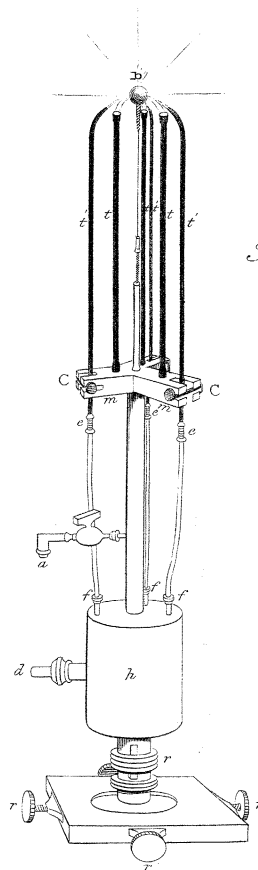

One Inch to Four Inches.

tages are detailed in a “*Mémoire sur un nouveau système d'éclairage*” by M. FRESNEL. The light which it gave is stated to possess $3\frac{1}{4}$ times the intensity of that given by a reflector. It was employed, during the operations alluded to, at Fairlight Down and Folkestone Hill on the English coast; at Cape Blancnez and Montlambert on the French coast: the greatest distance at which it was observed being 48 miles; and its appearance, I have understood from Colonel COLBY, was very brilliant.

But valuable as this apparatus may be when employed in a light-house, the purpose for which it was indeed invented and constructed, the properties of the simple parabolic reflector appeared still to give it a preference for the service of the Trigonometrical Survey, provided a more powerful light could be substituted in its focus, instead of the common argand lamp.

With this object in view, I at first endeavoured to make use of some of the most brilliant pyrotechnical preparations, then phosphorus burning in oxygen, with a contrivance to carry off the fumes of phosphoric acid was tried: but the first attempts with these substances promising but little success, they were abandoned. In all cases the flames, besides being difficult and troublesome to regulate, were large and unsteady; little adapted to the nature of a reflecting figure, which should obviously, when used to the utmost advantage, be lighted by a luminous sphere, the size being regulated by the spread required to be given to the light. This form of the focal light it was manifest, either could not be obtained or preserved when combustion was the source of light; and it was chiefly this consideration which then led me to attempt

applying, to the purpose in view, the brilliant light emanating from several of the earths when exposed to a high temperature; and at length I had the satisfaction of having an apparatus completed, by which a light so intense was produced, that when placed in the focus of a reflector the eye could with difficulty support its splendour, even at the distance of forty feet, the contour of the reflector being lost in the brilliancy of the radiation.

To obtain the requisite temperature, I had recourse to the known effect of a stream of oxygen directed through the flame of alcohol*, as a source of heat free from danger, easily procured and regulated, and of great intensity. Fig. 4 represents the apparatus such as it is now made for the survey. The spirit entering at *a*, ascends through the tubes *t*, while the oxygen entering at *d* is directed by the jets *t'* upon the small ball of lime *b*, the tubes *t'* are connected with the cylindrical box *h* by flexible caoutchouc tubes *ef*, and also pass with friction through small cylinders at *c*, which admit of being moved backwards and forwards upon the arms, and are clamped when in the proper position by small millheaded screws at the sides. By these means every requisite adjustment is obtained for the jets through which the gas issues. The apparatus is attached by its base to the stand which carries the reflector (fig. 3, Plate XII.) and the small ball may then, by means of the horizontal and vertical screws *r*, be brought with great accuracy into the focus of the reflector. The cistern *c* containing the alcohol is placed behind the reflector (fig. 3,) and being connected with the stem *a* by a flexible caoutchouc tube, may be elevated or depressed on

* Annals of Philosophy, vol. ii. p. 99.

the upright rod *r* fig. 3, and the flame of the spirit accordingly regulated so as to produce the greatest effect. A flexible tube leads from *d* to the vessel containing the oxygen, which may be either a common gas-holder, or perhaps a silk bag with a layer of caoutchouc, such as they are now made, might be conveniently employed for this purpose. The apparatus first made was provided with five jets, and could light up a ball $\frac{3}{8}$ inch in diameter; that now represented has only three, and with it a ball $\frac{1}{4}$ of an inch in diameter may be used sufficiently large to admit of the requisite allowance being made for aberration in the reflector from its true figure, as well as uncertainty of direction arising from terrestrial refraction.

To ascertain the relative intensities of the different incandescent substances that might be employed, they were referred, by the method of shadows, to an argand lamp as a common standard; the light from the brightest part of the flame being transmitted through apertures, equal in diameter to the small spheres of the different substances submitted to experiment.

The result of several trials made at the commencement gave for

Lime 37 times

Zirconia* 31 times

Magnesia 16 times the intensity of

an argand burner. The oxide of zinc was also tried; but besides wasting away rapidly, it proved inferior even to magnesia.

* From the description given by BERZELIUS of the light emitted by zirconia before the common blow-pipe, a different result might have been expected.

Of these substances, and also of their compounds with one another, lime appearing to possess a decided superiority, my subsequent experiments were confined to it alone, and by a more perfect adjustment of the apparatus, by bringing the maximum heat, which is confined within narrow limits, exactly to the surface of the ball, and by using smaller balls than those employed in the early experiments, a very material increase of light has been obtained. The mean of 10 experiments, made lately with every precaution, gives for the light emitted by lime, when exposed to this intense heat, 83 times the intensity of the brightest part of the flame of an argand burner of the best construction, and supplied with the finest oil. The lime from chalk, and such as is known at the London wharfs by the name of flame lime, appears to be more brilliant than any that has been tried.

When well burned Carrara marble is made into a paste with water, and gradually dried, it appears to be nearly equal to the preceding: when strongly compressed, or very porous, in both cases it is inferior.

The lime from the chalk, besides being the most brilliant, is in other respects very convenient for use; it admits of being turned in the lathe, and thus any number of the small focal balls, with slender stems attached to them, may be prepared with the utmost facility, uniform in size, and perfect in figure. The surface of the ball, by the continued action of the heat, appears to be kept nearly in a state of fusion; it is gradually worn down; and, on cooling, presents a semi-crystalline appearance. Being desirous of ascertaining what effect so intense a light would have on a mixture of chlorine and hydrogen, two tubes 10 inches long, with bulbs about

two inches in diameter blown at one extremity, were filled with a mixture of these gases, and placed within two inches of the luminous ball of lime, which was $\frac{3}{8}$ of an inch in diameter. The additional light, reflected by a concave mirror $9\frac{1}{2}$ inches in diameter, was also concentrated on one of the balls.

After some minutes exposure to the light the glass began to get dim, especially on the sides nearest the light, being covered with a thin whitish film; at the end of 15 minutes they were withdrawn, and the stop-cocks being opened, under water coloured with an infusion of litmus, it immediately rushed in, filling one-third of the ball on which the reflected light had also been concentrated, and one-half of the other exposed to the direct light only: the difference probably arising from some accidental inequality in the brightness of the opposite sides of the ball. The purple tint of the litmus was rapidly changed to red, which, again by the action of the uncombined portion of chlorine, gradually faded away, and was soon destroyed. The effect of the light on chloride of silver was equally remarkable. Three portions, one at the distance of about an inch from the luminous ball, the other four, and the third in the focus of the violet rays, concentrated by a powerful lens, were exposed to the influence of the light for twelve minutes, and were then found to be completely discoloured; that nearest the light being almost black, the other two having a brownish black hue. Having now described the instruments contrived to facilitate the observation of the distant stations of the survey, it may not perhaps be uninteresting to add an account of their successful application to a case of considerable importance and difficulty, that occurred at the end of last season.

Slieve Snaght, the highest hill of Innishowen, about 2100 feet above the sea, and 15 miles N. of Londonderry, forms an important point in the triangulation, which connects the North of Ireland with the western islands of Scotland.

On the 23d of August last a conspicuous object was placed on its summit, that it might be observed from the Divvis Hill, near Belfast, where we were then encamped. Having continued, however, till the 26th October, enveloped in a haze so impenetrable as to render unavailing every effort made for this purpose, Colonel COLBY resolved, although the season was far advanced and the weather unsettled, that an attempt should be made to surmount this formidable obstacle, by the aid of the instruments now described. By his directions I proceeded with a party of men to the hill in question, which we reached on the 27th October. For the first ten or twelve days after our arrival we had to struggle against most tempestuous weather, and being only provided with round tents, which resisted but for a short time the violence of the successive gales, it was with some difficulty and exertion that we maintained ourselves on the hill, and preserved the instruments themselves from destruction. At length, however, the weather becoming moderate, both instruments were brought into use, and we had the satisfaction of learning from Lieutenants HENDERSON and MURPHY, to whom Colonel COLBY had confided the task of completing the observations, and whose vigilance the first glimpse of the light did not escape, that on the 9th and 10th of November both instruments had been brilliantly visible, and the observations in consequence brought to a satisfactory conclusion. The distance between the stations is $66\frac{1}{4}$ miles; but the difficulty

experienced in observing Slieve Snaght appears to have arisen not so much from the distance, as from the direction passing over a range of other hills, and not far above their tops. Of twelve observations, made during the day, on the ninth and tenth of November, not more than one could have been effected without the aid of the heliostat, and many were obtained when the outline of the hill itself had ceased to be visible. The light at night was referred to a 15 inch parabolic reflector, illuminated by an argand lamp, and placed on the church tower of Randalstown, nearly in the same direction. The light on the distant hill was not only seen with the naked eye, but appeared much brighter and larger than that at Randalstown, their relative distances being nearly 67 and 15 miles. Colonel COLBY proposes employing this light to effect the observation of Ben Lomond from Knock Layd, in the north-east extremity of Ireland, a distance of not less than 95 miles; and availing himself of the position of Ben Lomond, which commands a view of the Observatory on the Calton Hill of Edinburgh, to determine by simultaneous observations, the difference of longitude between it and Knock Layd, which is nearly in the meridian of the Dublin Observatory.

It may perhaps be asked, if this mode of producing light does not admit of being applied to other purposes, besides those of a Trigonometrical Survey: and, that, which naturally suggests itself, as a very extensive and important application, is the illumination of light-houses. Not being subject to explosion, it might be employed without incurring the slightest danger: and the apparatus, when fixed and permanent, might be rendered so simple, that the most ordinary care and attention

would be sufficient for its management. Even on the survey this requires no peculiar address, notwithstanding the inconveniences of very exposed situations, and the necessity of rendering every article as portable as possible. The expense may appear, at first sight, the strongest objection to its general use; but, supposing rectified spirits to be employed, with the duty remitted, and no further use to be made of the oxide of manganese, after the abstraction of the oxygen,* it may be stated, in general terms, that while the intensity of light varies between 60 and 90 times that of an argand lamp, the expense would not exceed ten times. Applied to a revolving light, where four sides are illuminated, each with four reflectors, one reflector, with the lime light, might be substituted on each side, and with an increased expense of $2\frac{1}{2}$ times that of the oil an intensity varying between 15 and 22 would be obtained. It will also be recollected that the oil consumed is far from constituting the most considerable portion of the expense of maintaining a light-house, and that it would probably not be underrated if estimated on an average at one-fourth. The other sources of expenditure would, in both cases, be the same. How far this increased expense would be an objection to its general introduction into light-houses, is for others to determine; but there are, I should apprehend, situations, such for example, as the Lizard Point, the Scilly Islands, or the great Skellig,† off the south-west extremity of Ireland, where the advantages of so powerful a light would

* It is not improbable that some simple process might be found for causing the manganese to absorb from the atmosphere the oxygen which it had lost by exposure to heat; in this case the expense would be diminished about two-thirds.

† A light-house is now building on this remarkable rock, which will be of great importance, being the first made by vessels from America.

not be considered too dearly purchased at such a price. Whether it would be most advantageous to collect the light with common parabolic reflectors, or to adopt the system of lenses and plane reflectors, proposed by M. FRESNEL, with such modifications as the peculiar nature of the light might admit or require, would readily be determined by experiment. There are good grounds for believing that this latter mode would be found the most economical and effective ; and that a light-house might be brilliantly illuminated by a single ball of lime ; in which case the expense would not exceed, if it equalled that of oil. It might not be uninteresting at the same time, to enquire what degree of light could be obtained from lime, by employing atmospheric air with common oil or tallow, as the source of heat. From some rough experiments made with this view, it seemed not improbable that it would possess considerable superiority over that of an argand lamp. But whatever might be the result of these enquiries, it will probably be admitted that enough has already been practically carried into effect, to show that no formidable difficulty stands in the way of the application of this mode of illumination to light-houses, and that the subject is not undeserving the attention of those, to whose charge these important establishments are committed.